



CMD158C4

6-16 GHz Driver Amplifier

Features

- ▶ Broadband performance
- ▶ High output power
- ▶ Low current consumption
- ▶ Single supply voltage: +5.0 V @ 95 mA
- ▶ Pb-free RoHs compliant 4x4 QFN package

Description

The CMD158C4 is a broadband MMIC driver amplifier housed in a leadless 4x4 mm surface mount package. The CMD158C4 is ideally suited for EW and communications systems where small size and low power consumption are needed. The broadband device delivers 21 dB of gain and +21 dBm saturated output power at 24 % PAE from a single 5 V supply. The CMD158C4 is a 50 ohm matched design eliminating the need for external DC blocks and RF port matching.

Functional Block Diagram

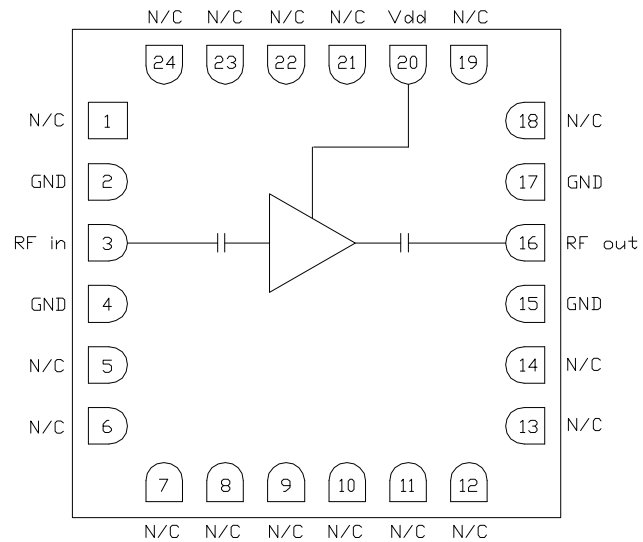

Electrical Performance - $V_{dd} = 5.0 \text{ V}$, $T_A = 25 \text{ }^\circ\text{C}$, $F = 11 \text{ GHz}$

Parameter	Min	Typ	Max	Units
Frequency Range	6 - 16			GHz
Gain		21		dB
Input Return Loss		19		dB
Output Return Loss		13		dB
Output P1dB		20		dBm
Output Psat		21		dBm
Supply Current		95		mA

ver 1.3 1016



CMD158C4

6-16 GHz Driver Amplifier

Specifications

Absolute Maximum Ratings

Parameter	Rating
Drain Voltage, V _{dd}	6.5 V
RF Input Power	+23 dBm
Channel Temperature, T _{ch}	150 °C
Power Dissipation, P _{diss}	535 mW
Thermal Resistance	122 °C/W
Operating Temperature	-40 to 85 °C
Storage Temperature	-55 to 150 °C

Operation of this device outside the maximum ratings may cause permanent damage.

Recommended Operating Conditions

Parameter	Min	Typ	Max	Units
V _{dd}	3.0	5.0	6.0	V
I _{dd}		95		mA

Electrical performance is measured at specific test conditions. Electrical specifications are not guaranteed over all recommended operating conditions.

Electrical Specifications - V_{dd} = 5.0 V, T_A = 25 °C

Parameter	Min	Typ	Max	Min	Typ	Max	Units
Frequency Range	6 - 9			9 - 16			GHz
Gain	15	21	25	17	21	25	dB
Noise Figure		5.5			3.5		dB
Input Return Loss		13			15		dB
Output Return Loss		17			12		dB
Output P _{1dB}	16.5	19.5		17.5	20		dBm
Output IP ₃		24			26		dBm
Supply Current	70	95	120	70	95	120	mA
Gain Temperature Coefficient		0.012			0.012		dB/°C

ver 1.3 1016

Typical Performance

Broadband Performance, $V_{dd} = 5.0 \text{ V}$, $I_{dd} = 95 \text{ mA}$, $T_A = 25 \text{ }^\circ\text{C}$

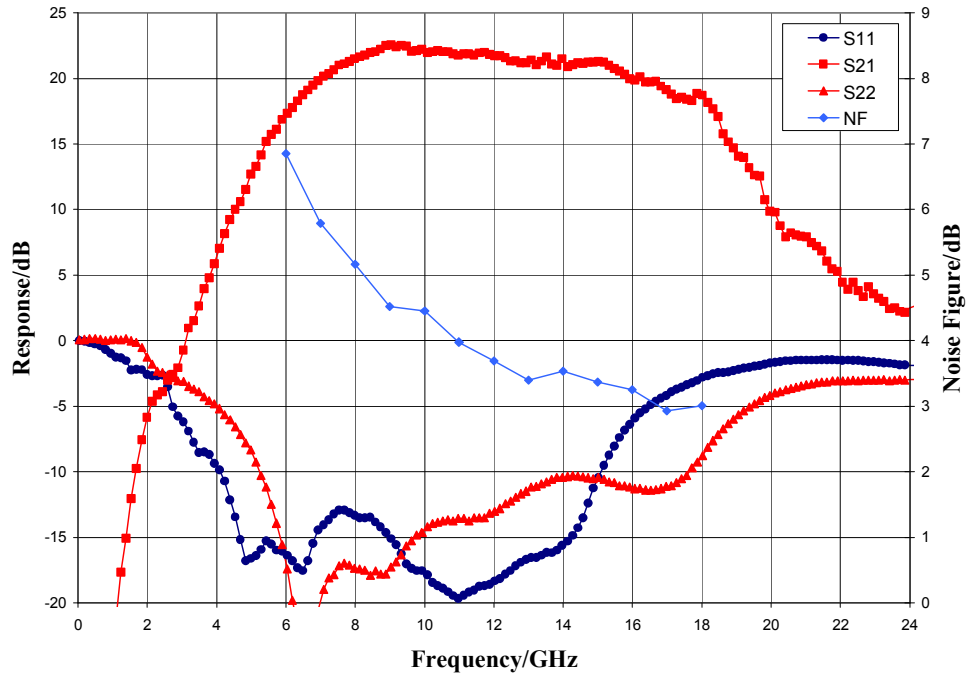

Narrow-band Performance, $V_{dd} = 5.0 \text{ V}$, $I_{dd} = 95 \text{ mA}$, $T_A = 25 \text{ }^\circ\text{C}$

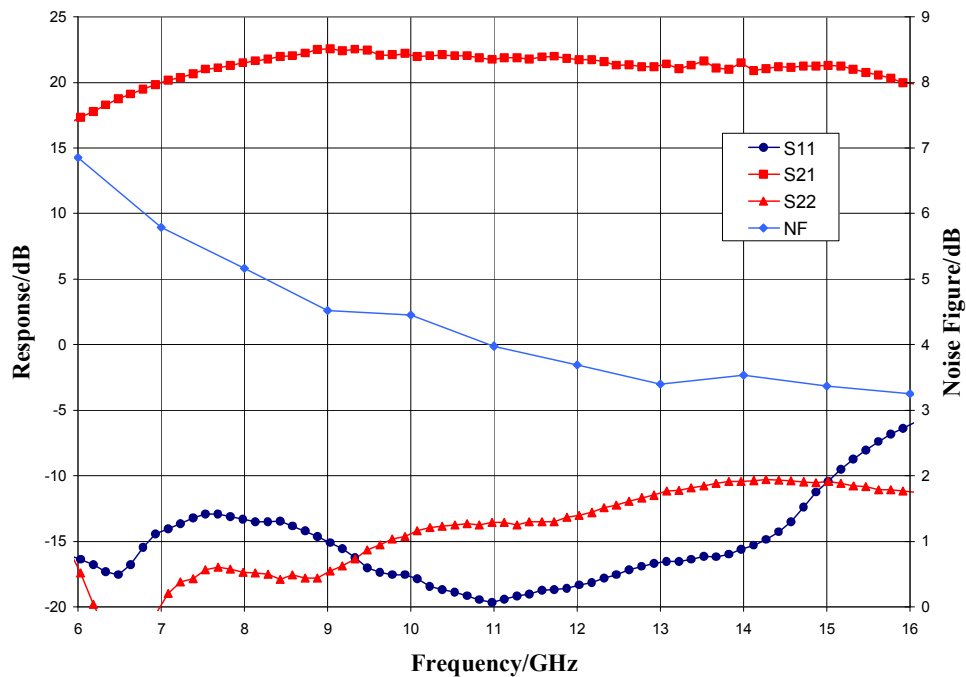

ver 1.3 1016

Typical Performance

Gain vs. Temperature, $V_{dd} = 5.0\text{ V}$

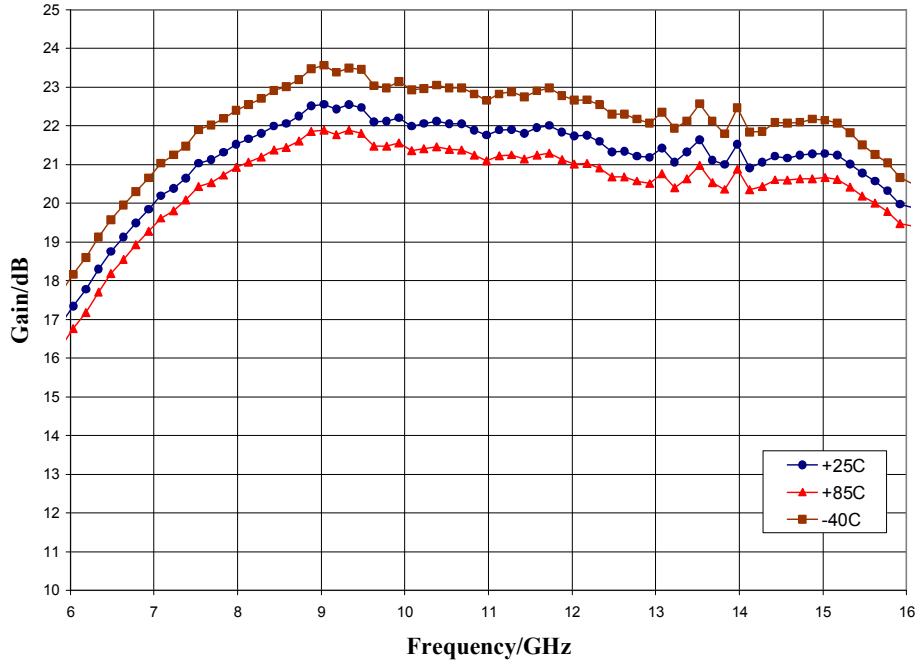

Output Power, $V_{dd} = 5.0\text{ V}$, $I_{dd} = 95\text{ mA}$, $T_A = 25\text{ }^\circ\text{C}$

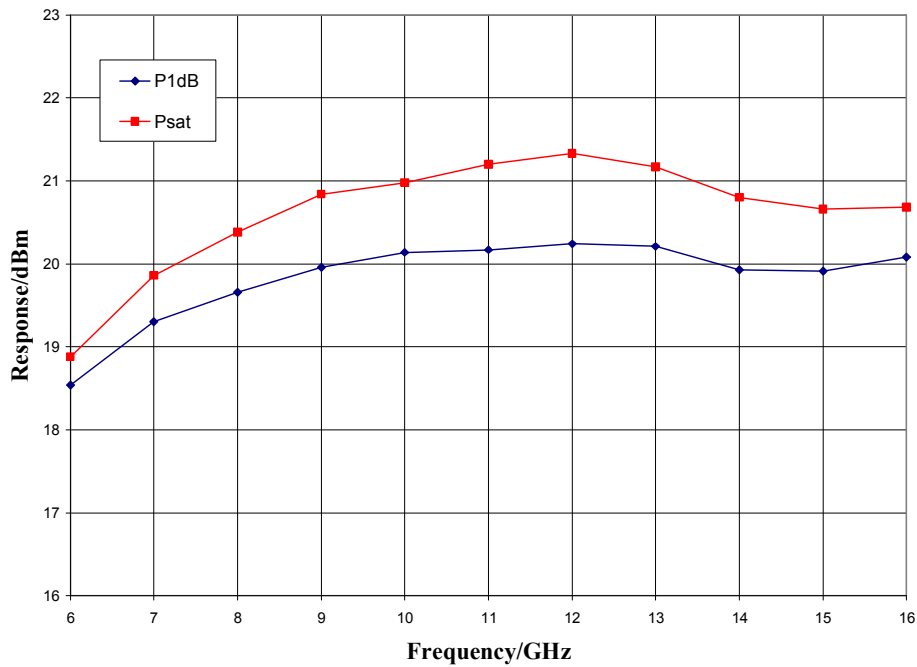

ver 1.3 1016

Typical Performance

P1dB vs. Temperature, $V_{dd} = 5.0\text{ V}$

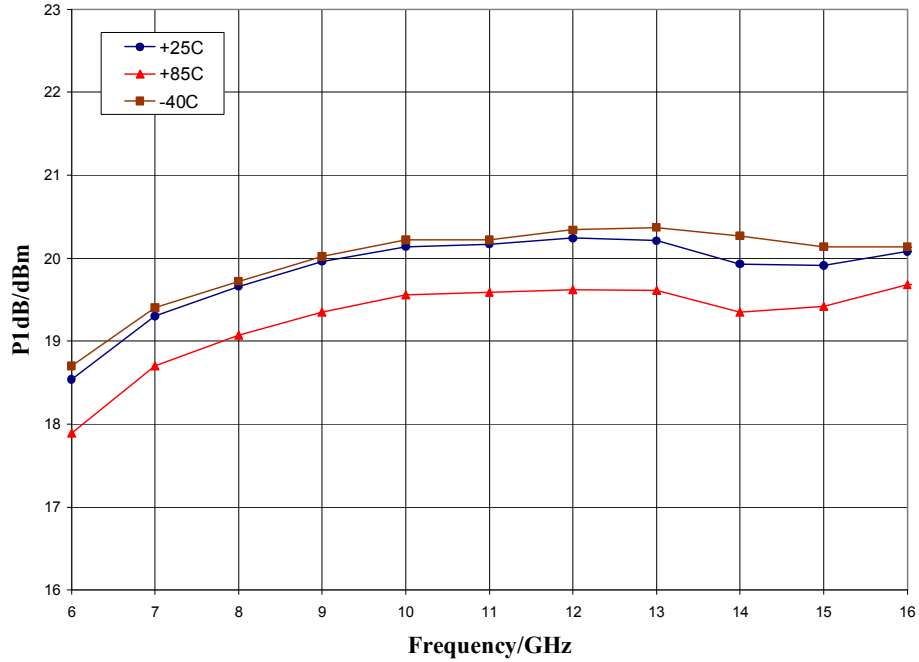

Output IP3, $V_{dd} = 5.0\text{ V}$, $I_{dd} = 95\text{ mA}$, $T_A = 25\text{ }^\circ\text{C}$

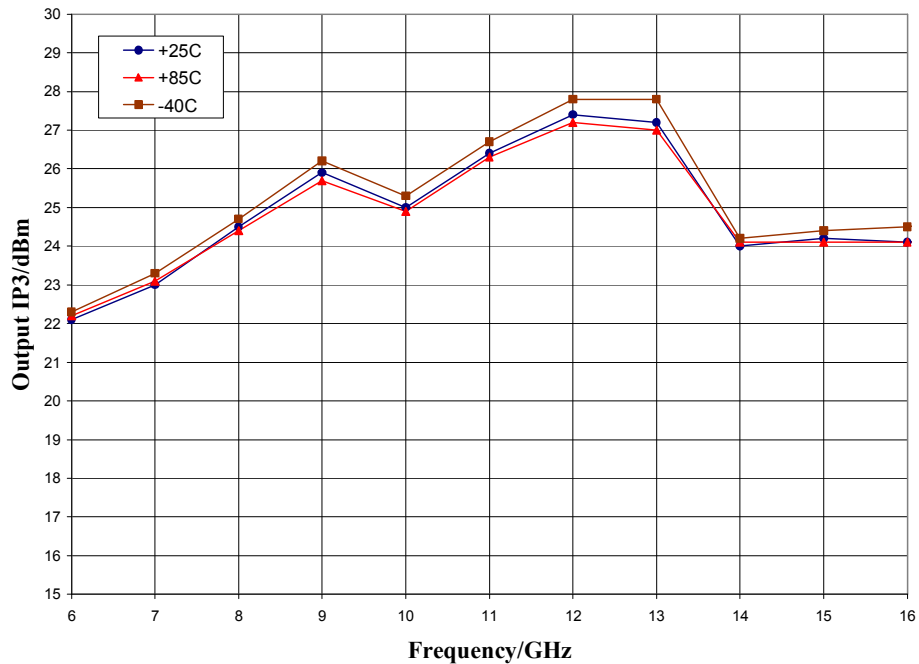

ver 1.3 1016

Typical Performance

Noise Figure vs. Temperature, $V_{dd} = 5.0\text{ V}$

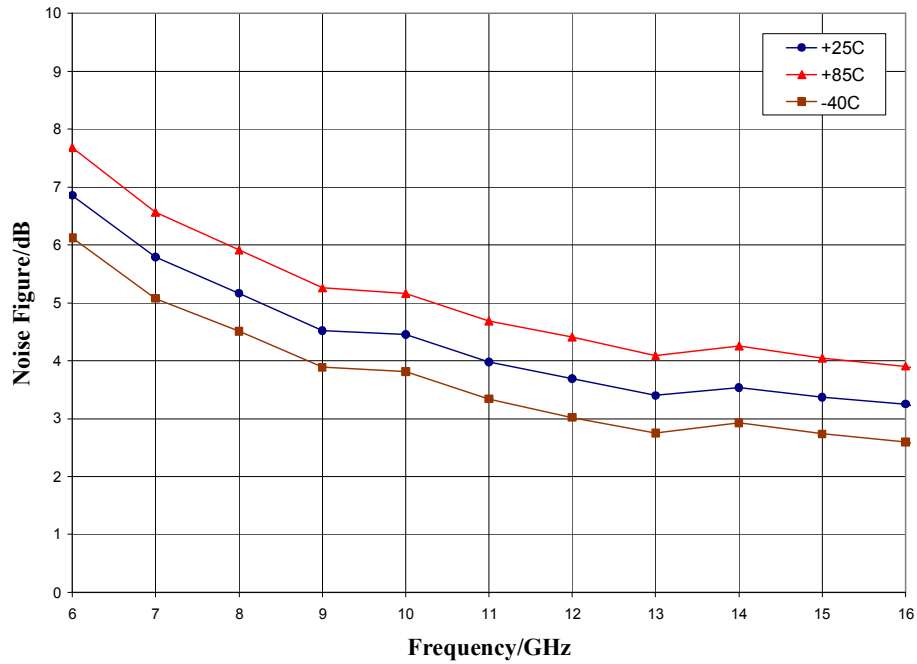

Mechanical Information

Package Information and Dimensions

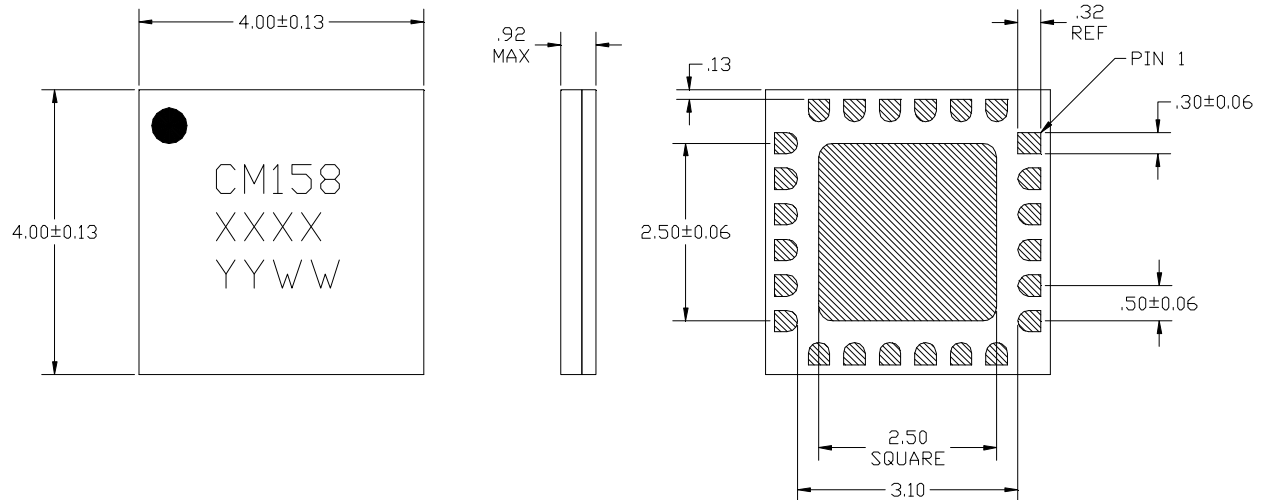

NOTES:

1. DIMENSIONS ARE IN MILLIMETERS
2. MATERIAL: BLACK ALUMINA
3. LEAD FINISH: 30-80 MICRONS GOLD OVER 50 MICRONS NICKEL.
4. ALTERNATE PIN #1 IDENTIFIER IS SINGLE SQUARE PAD.

Recommended PCB Land Pattern

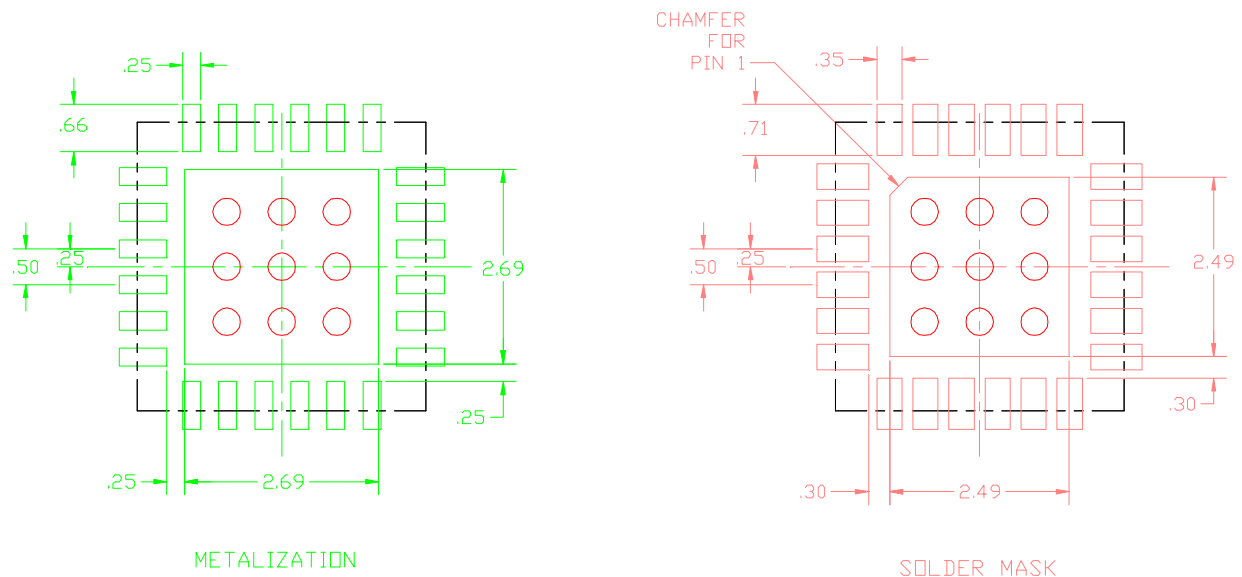

ver 1.3 1016

Pin Description

Pin Diagram

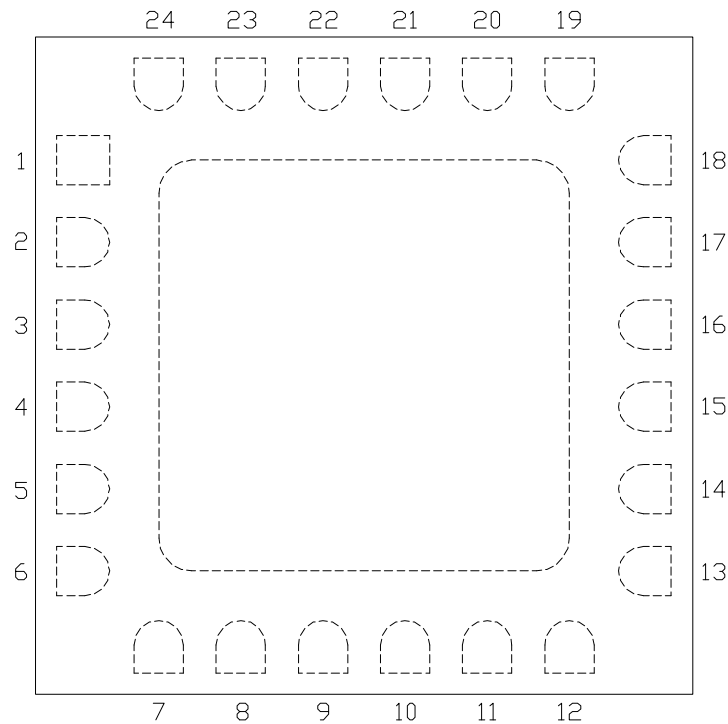

Functional Description

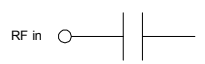
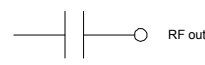
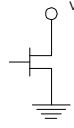
Pin	Function	Description	Schematic
1, 5-14, 18, 19, 21-24	N/C	No connection required. These pins may be connected to RF/DC ground	
2, 4, 15, 17 and die paddle	Ground	Connect to RF/DC ground	
3	RF in	DC blocked and 50 ohm matched	
16	RF out	DC blocked and 50 ohm matched	
20	Vdd	Power supply voltage Decoupling and bypass caps required	

ver 1.3 1016

Applications Information

Application Circuit

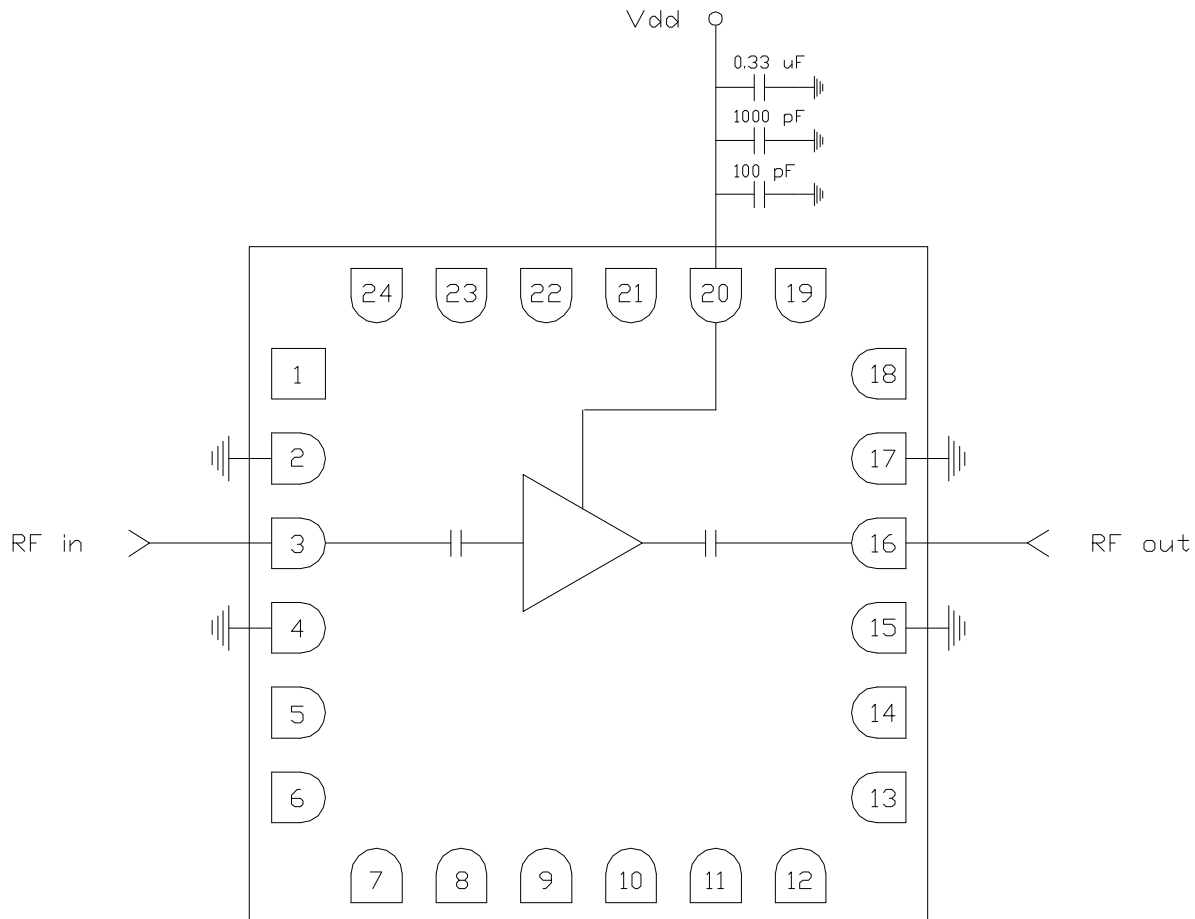

Biasing and Operation

The CMD158C4 is biased with a single 5.0 V positive drain supply.

RF power can be applied at any time.

GaAs MMIC devices are susceptible to damage from Electrostatic Discharge. Proper precautions should be observed during handling, assembly and test.

ver 1.3 1016

Applications Information

Evaluation Board

The circuit board shown has been developed for optimized assembly at CMDS. A sufficient number of via holes should be used to connect the top and bottom ground planes. As surface mount processes vary, careful process development is recommended.

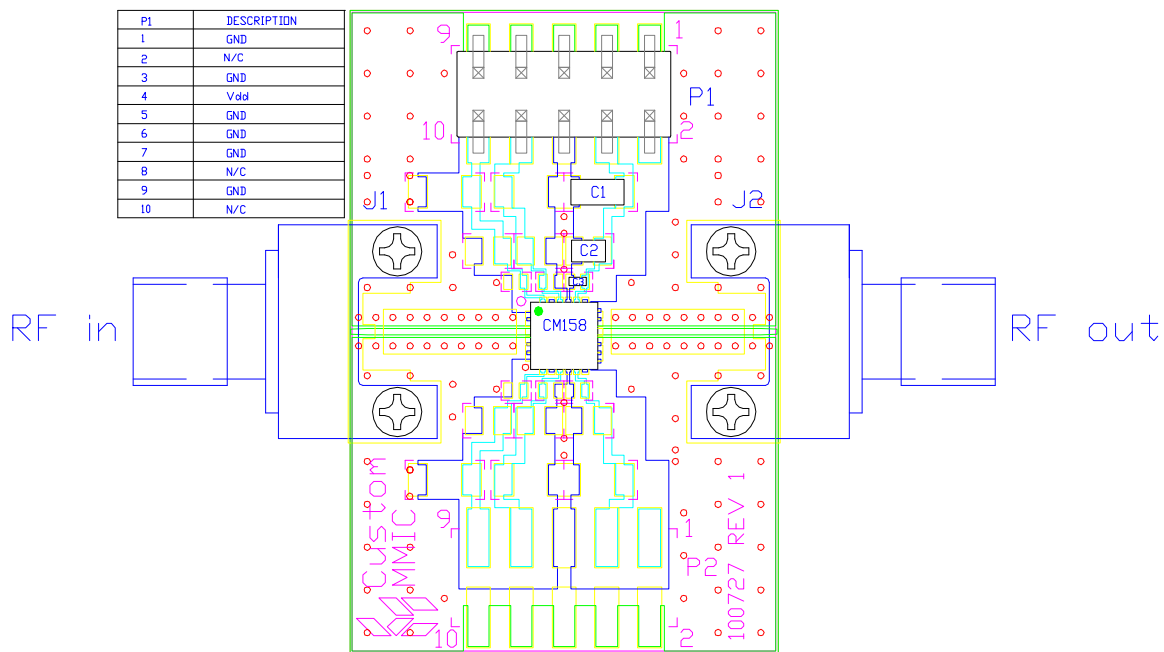

Bill of Material

Designator	Value	Description
J1, J2		SMA End Launch Connector
P1		10 Pin Header
C1	0.33 μ F	Capacitor, Tantalum
C2	1000 pF	Capacitor, 0603
C3	100 pF	Capacitor, 0402
U1		CMD158C4 Low Noise Amplifier
PCB		100727 Evaluation PCB

ver 1.3 1016