

CMD132

5-11 GHz Low Noise Amplifier

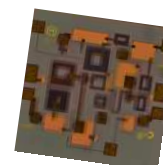

Features

- ▶ Ultra low noise figure
- ▶ Low current consumption
- ▶ High gain broadband performance
- ▶ Single supply voltage: +3.6 V @ 30 mA
- ▶ Small die size

Applications

- ▶ Point-to-point radios
- ▶ Point-to-multi-point radios
- ▶ Military and Space
- ▶ Test instrumentation

Description

The CMD132 is a broadband MMIC low noise amplifier ideally suited for microwave radios and C and X-band applications where small size and low power consumption are needed. The broadband device delivers greater than 22 dB of gain with a corresponding output 1 dB compression point of +10 dBm and a noise figure of 1.4 dB. The CMD132 is a 50 ohm matched design eliminating the need for external DC blocks and RF port matching. The CMD132 amplifier is the perfect alternative to costly hybrid amplifiers.

Functional Block Diagram

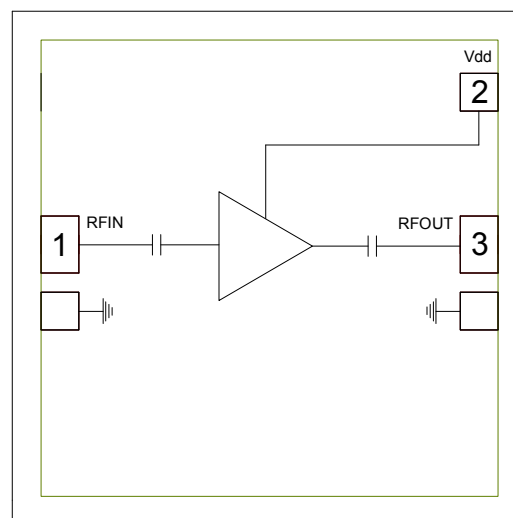

Electrical Performance - $V_{dd} = 3.6\text{ V}$, $T_A = 25\text{ }^\circ\text{C}$

Parameter	Min	Typ	Max	Units
Frequency Range	5 - 11			GHz
Gain		23		dB
Noise Figure		1.4		dB
Input Return Loss		10		dB
Output Return Loss		17		dB
Output P1dB		10		dBm
Supply Current		30		mA

ver 1.0 0112



CMD132

5-11 GHz Low Noise Amplifier

Specifications

Absolute Maximum Ratings

Parameter	Rating
Drain Voltage, Vdd	5.0 V
RF Input Power	+20 dBm
Channel Temperature, Tch	150 °C
Power Dissipation, P _{diss}	367 mW
Thermal Resistance	177 °C/W
Operating Temperature	-55 to 85 °C
Storage Temperature	-55 to 150 °C

Operation of this device outside the maximum ratings may cause permanent damage.

Recommended Operating Conditions

Parameter	Min	Typ	Max	Units
Vdd	2.0	3.6	4.5	V
I _{dd}		30		mA

Electrical performance is measured at specific test conditions. Electrical specifications are not guaranteed over all recommended operating conditions.

Electrical Specifications - V_{dd} = 3.6 V, T_A = 25 °C

Parameter	Min	Typ	Max	Min	Typ	Max	Units
Frequency Range	5 - 8.5			8.5 - 11			GHz
Gain	21	24	27	19	22	25	dB
Noise Figure		1.7	2.3		1.3	1.7	dB
Input Return Loss		9			11		dB
Output Return Loss		17			18		dB
Output P1dB		10			11		dBm
Output IP3		22			22.5		dBm
Supply Current	21	30	39	21	30	39	mA
Gain Temperature Coefficient		0.015			0.015		dB/°C
Noise Figure Temperature Coefficient		0.008			0.008		dB/°C

ver 1.0 0112



CMD132

5-11 GHz Low Noise Amplifier

Typical Performance

Broadband Performance, $V_{dd} = 3.6\text{ V}$, $I_{dd} = 30\text{ mA}$, $T_A = 25\text{ }^\circ\text{C}$

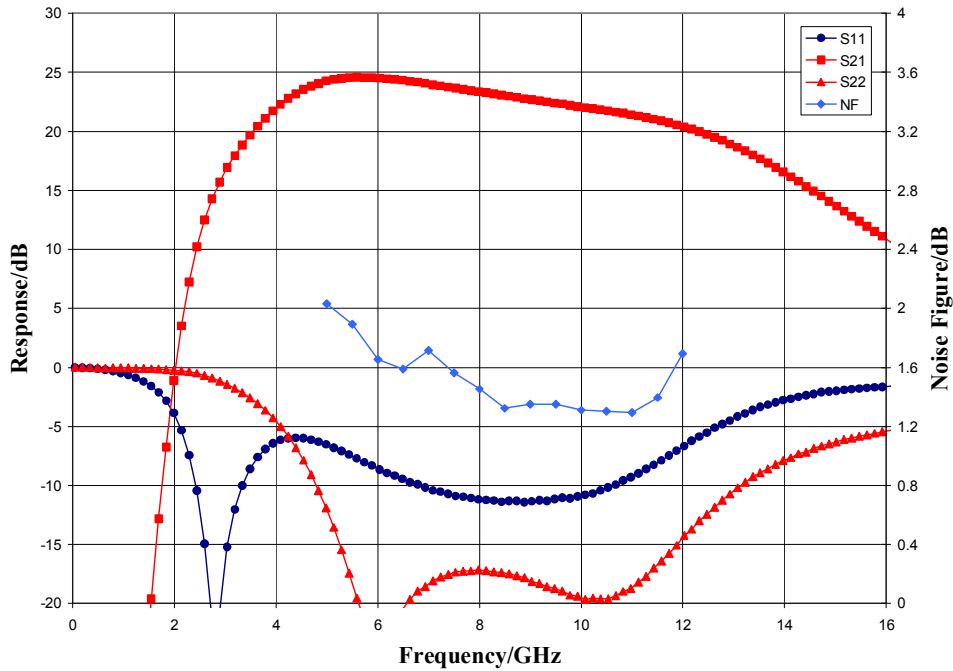

Narrow-band Performance, $V_{dd} = 3.6\text{ V}$, $I_{dd} = 30\text{ mA}$, $T_A = 25\text{ }^\circ\text{C}$

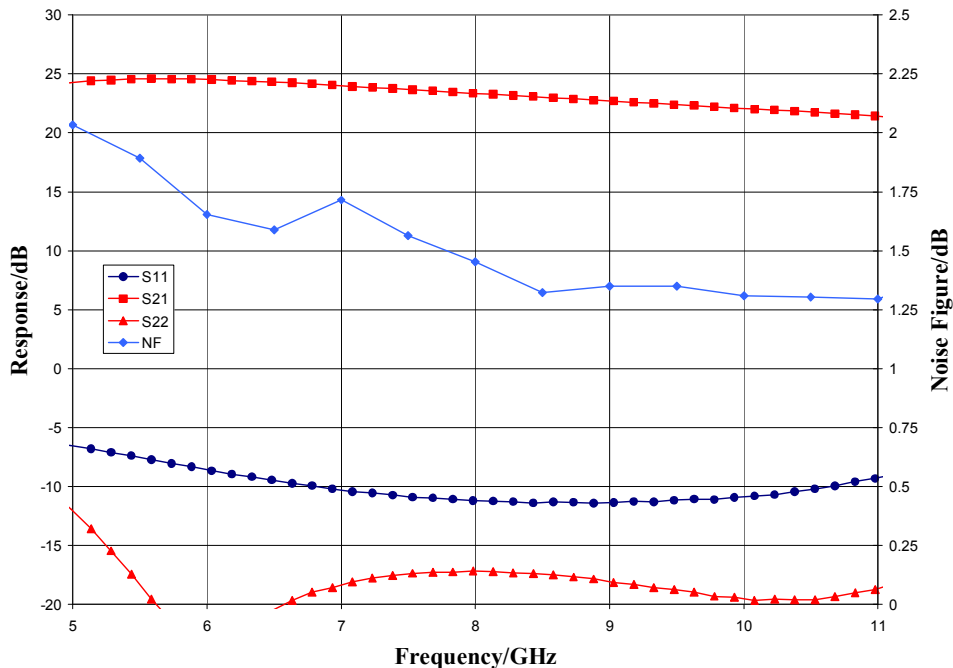

ver 1.0 0112



CMD132

5-11 GHz Low Noise Amplifier

Typical Performance

Gain vs. Temperature, $V_{dd} = 3.6\text{ V}$

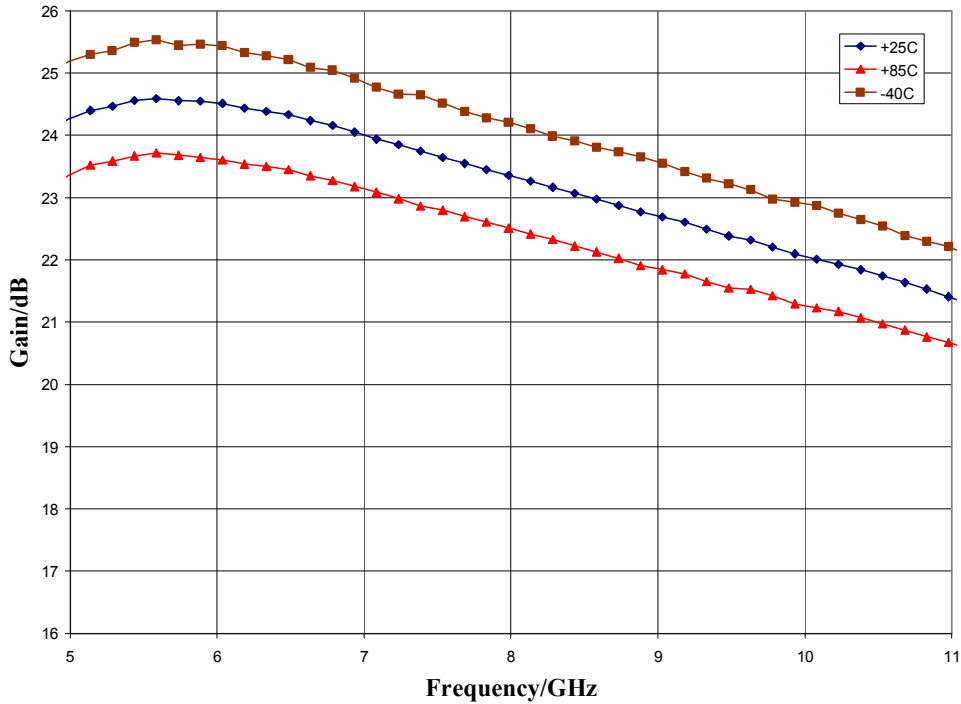

Noise Figure vs. Temperature, $V_{dd} = 3.6\text{ V}$

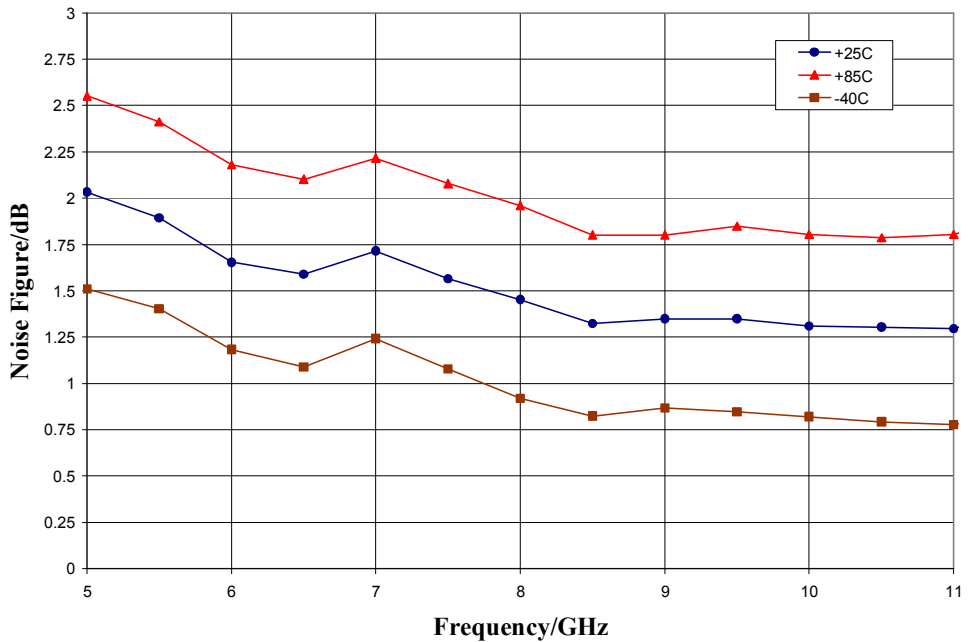

ver 1.0 0112



CMD132

5-11 GHz Low Noise Amplifier

Typical Performance

Output Power, $V_{dd} = 3.6\text{ V}$, $I_{dd} = 30\text{ mA}$, $T_A = 25\text{ }^\circ\text{C}$

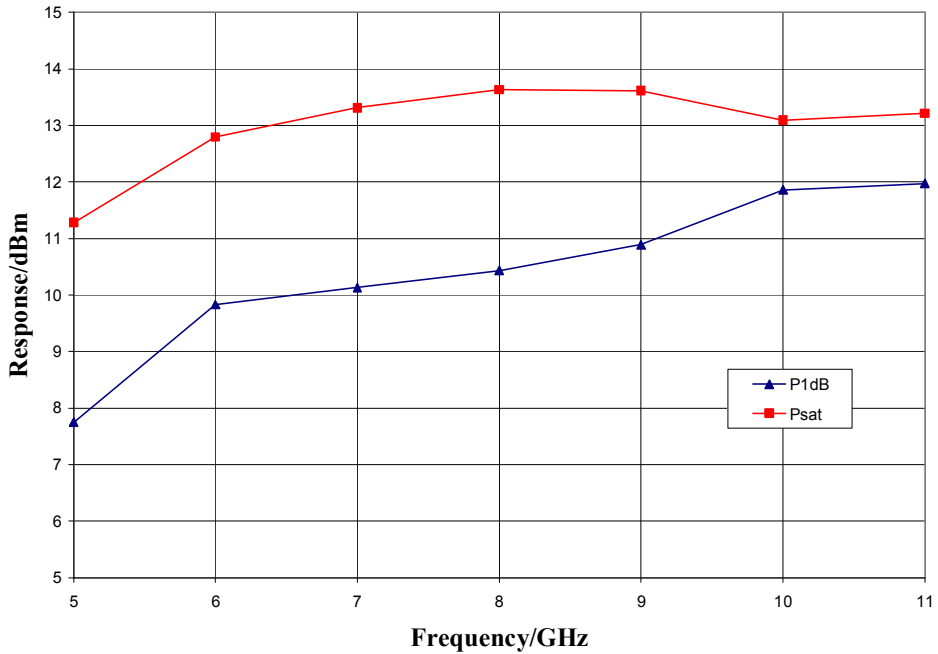

Output IP3, $V_{dd} = 3.6\text{ V}$, $I_{dd} = 30\text{ mA}$, $T_A = 25\text{ }^\circ\text{C}$

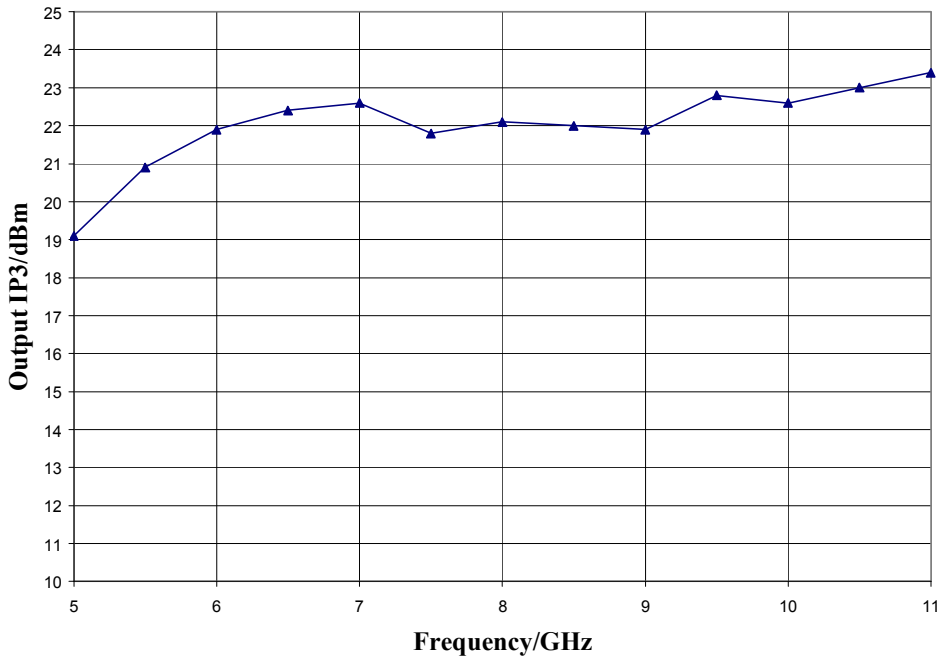

ver 1.0 0112

Mechanical Information

Die Outline (all dimensions in microns)

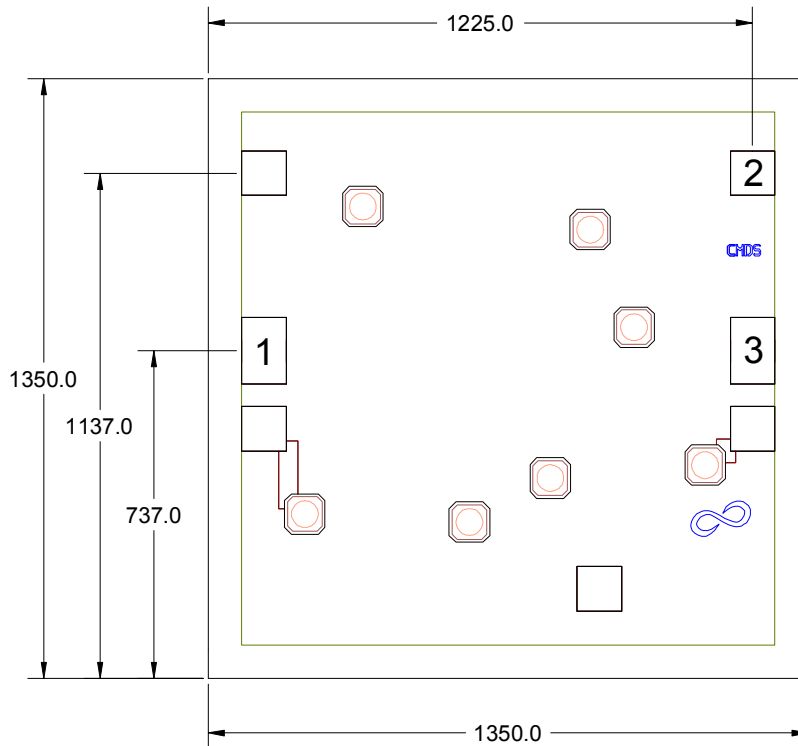

Notes:

1. No connection required for unlabeled pads
2. Backside is RF and DC ground
3. Backside and bond pad metal: Gold
4. Die is 100 microns thick
5. DC bond pads are 100 microns square



CMD132

5-11 GHz Low Noise Amplifier

Pad Description

Pad Diagram

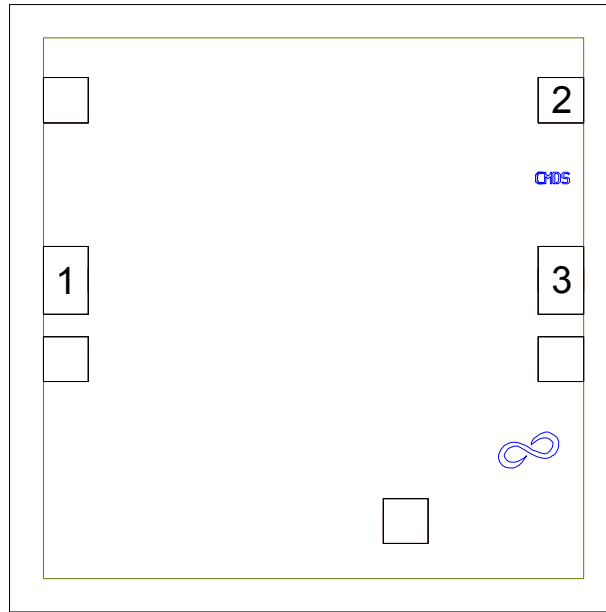

Functional Description

Pad	Function	Description	Schematic
1	RF in	DC blocked and 50 ohm matched	
2	Vdd	Power supply voltage Decoupling and bypass caps required	
3	RF out	DC blocked and 50 ohm matched	
Backside	Ground	Connect to RF / DC ground	

ver 1.0 0112



CMD132

5-11 GHz Low Noise Amplifier

Applications Information

Assembly Guidelines

The backside of the CMD132 is RF ground. For microstrip applications, the die should be electrically and thermally epoxied to a sound heat sink. Standard assembly procedures should be followed for high frequency devices. The top surface of the semiconductor should be made planar to the adjacent RF transmission lines, and the RF decoupling capacitors placed in close proximity to the DC connections on chip.

RF connections should be made as short as possible to reduce the inductive effect of the bond wire. Use of a 0.8 mil thermosonic wedge bonding is highly recommended as the loop height will be minimized. The RF input and output require a double bond wire as shown.

The semiconductor is 100 um thick and should be handled by the sides of the die or with a custom collet. Do not make contact directly with the die surface as this will damage the monolithic circuitry. Handle with care.

Assembly Diagram

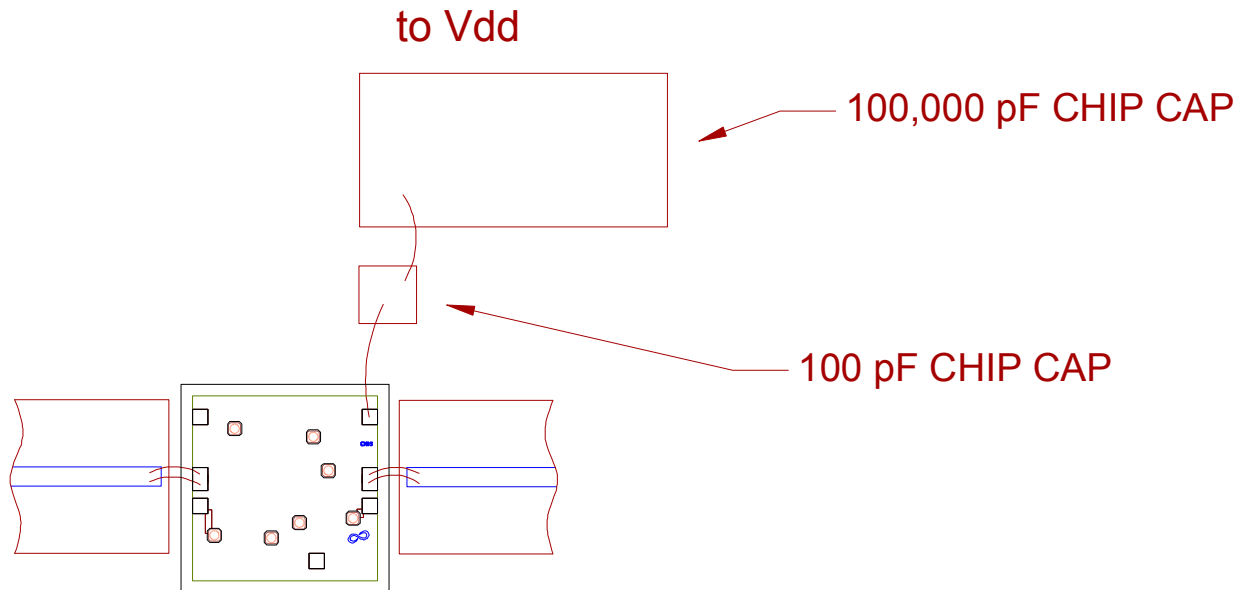

ver 1.0 0112



CMD132

5-11 GHz Low Noise Amplifier

Applications Information

Biasing and Operation

The CMD132 is biased with a positive drain supply. Performance is optimized when the drain voltage is set to +3.6 V, though it may be set to a minimum of +2.0 V and a maximum of +4.5 V.

Turn ON procedure:

1. Apply drain voltage V_{dd} and set to +3.6 V

Turn OFF procedure:

1. Turn off drain voltage V_{dd}

RF power can be applied at any time.

ver 1.0 0112